

INLET FLANGE DETAIL

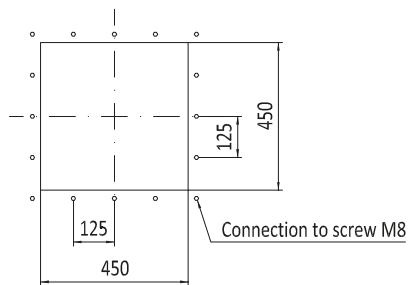

OUTLET FLANGE DETAIL

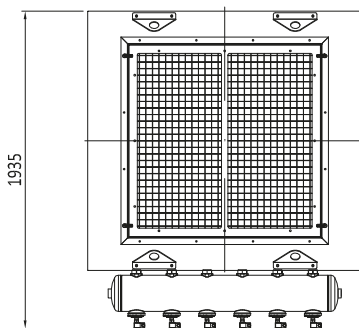
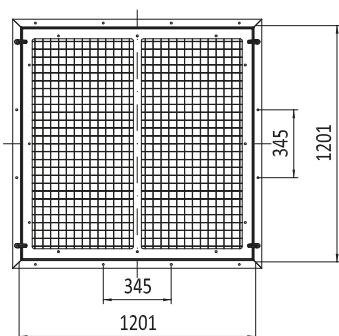

* The level of sound pressure is affected by the background noise, the reverberation of the environment, the presence of other sound sources and the positioning of the machine near reflecting surfaces. In the installations common conditions it is necessary to use corrective coefficients. This value depends also from the level of sound pressure of the fan.

| TECHNICAL SPECIFICATIONS | | |
|---|--|--------------|
| ITEM CODE | AC-DC 9000 | |
| Certification code | II 3 D Ex h III C T200°C Dc -10°C:T<40°C | |
| Weight | kg | 1600 |
| Number of filtering elements | nr | 9 |
| Filtering surface | m ² | 135 |
| Max working negative pressure | Pa | 5000 |
| Working Temperature | °C | -10<T<40 |
| Pneumatic feeding (ISO Class 2.4.1 according 8573-1:2010) | Ø | 1"1/2 GAS |
| Electric fan feeding | 400tr / 690st V AC 50 Hz | |
| Electric control panel feeding | 230 V AC 50Hz | |
| Cartridge cleaning system | pulse-jet | |
| Number of cleaning valves | nr | 6 |
| Type of cleaning valves | Ø 1" 1/2 - 24 V DC | |
| Compressed air tank working pressure | bar | 5 |
| PERFORMANCE CHARACTERISTICS | | |
| Nominal air flow | m ³ /h | 9000 |
| Nominal static pressure | Pa | 4400 |
| Nominal fan power | kW | 18.5 |
| Max compressed air consumption | NI/min | 651 |
| Average level of sound pressure LpA_1.5m (UNIS EN ISO 3746:1997) | dB(A) | <80 |

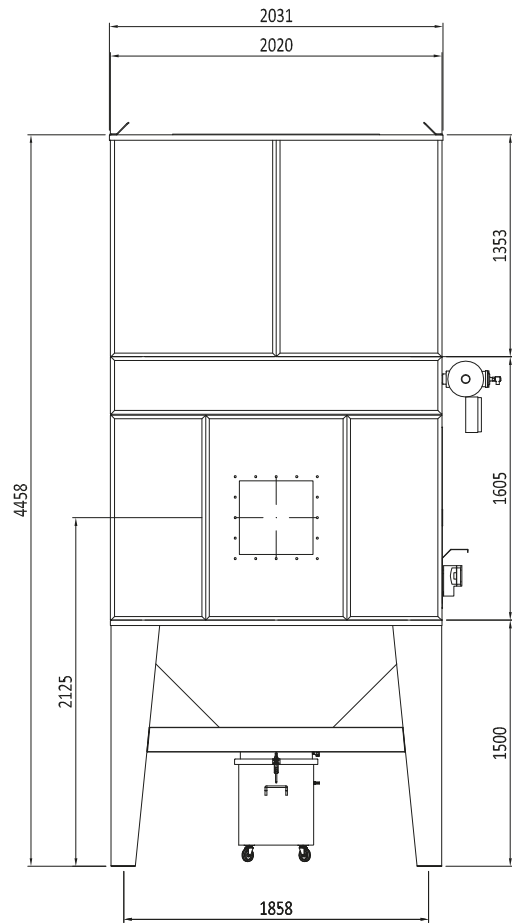
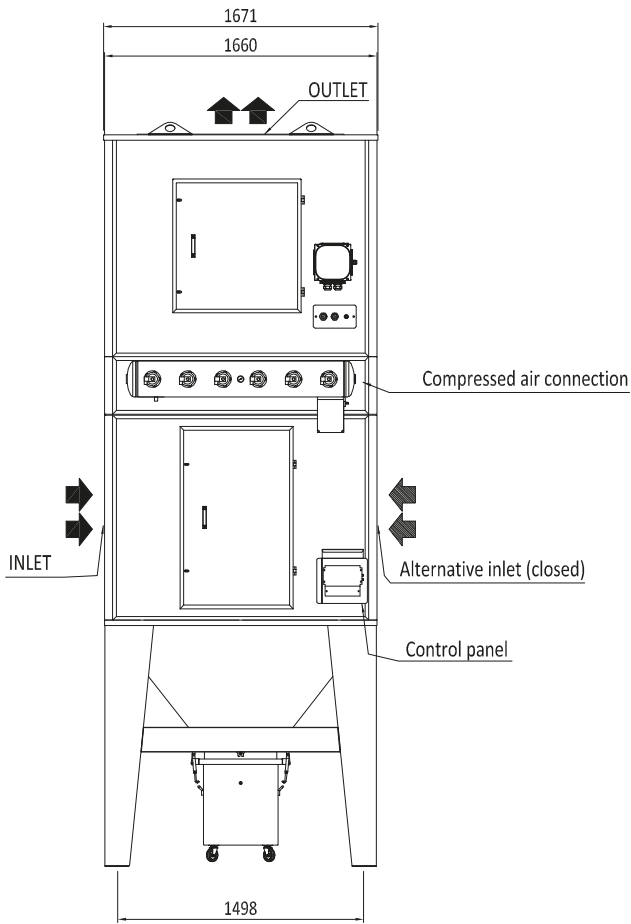

INLET FLANGE DETAIL

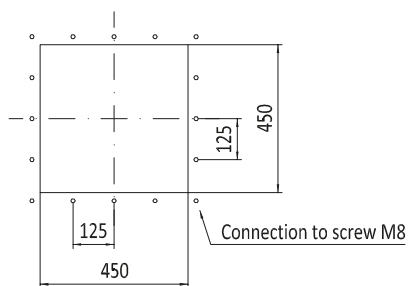
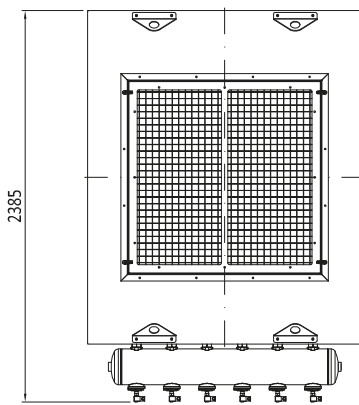

OUTLET FLANGE DETAIL

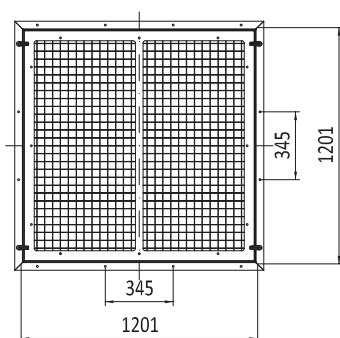

* The level of sound pressure is affected by the background noise, the reverberation of the environment, the presence of other sound sources and the positioning of the machine near reflecting surfaces. In the installations common conditions it is necessary to use corrective coefficients. This value depends also from the level of sound pressure of the fan.

| TECHNICAL SPECIFICATIONS | | |
|--|--|------------|
| ITEM CODE | AC-DC 12000 | |
| Certification code | II 3 D Ex h III C T200°C Dc -10°C:T:40°C | |
| Weight | kg | 1900 |
| Number of filtering elements | nr | 12 |
| Filtering surface | m ² | 180 |
| Max working negative pressure | Pa | 5000 |
| Working Temperature | °C | -10<T:40 |
| Pneumatic feeding (ISO Class 2.4.1 according 8573-1:2010) | Ø | 1" 1/2 GAS |
| Electric fan feeding | 400tr / 690st V AC 50 Hz | |
| Electric control panel feeding | 230 V AC 50Hz | |
| Cartridge cleaning system | pulse-jet | |
| Number of cleaning valves | nr | 6 |
| Type of cleaning valves | Ø 1" 1/2 - 24 V DC | |
| Compressed air tank working pressure | bar | 5 |
| PERFORMANCE CHARACTERISTICS | | |
| Nominal air flow | m ³ /h | 12000 |
| Nominal static pressure | Pa | 4700 |
| Nominal fan power | kW | 22 |
| Max compressed air consumption | NI/min | 651 |
| Average level of sound pressure LpA_1.5m (UNIS EN ISO 3746:1997) | dB(A) | <80 |

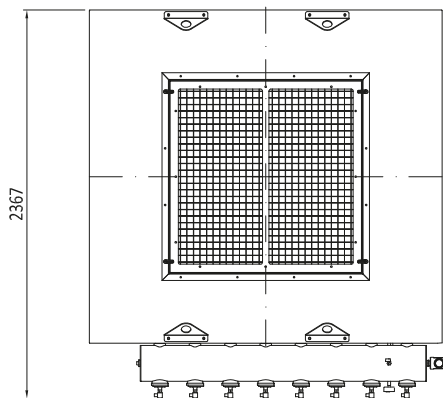
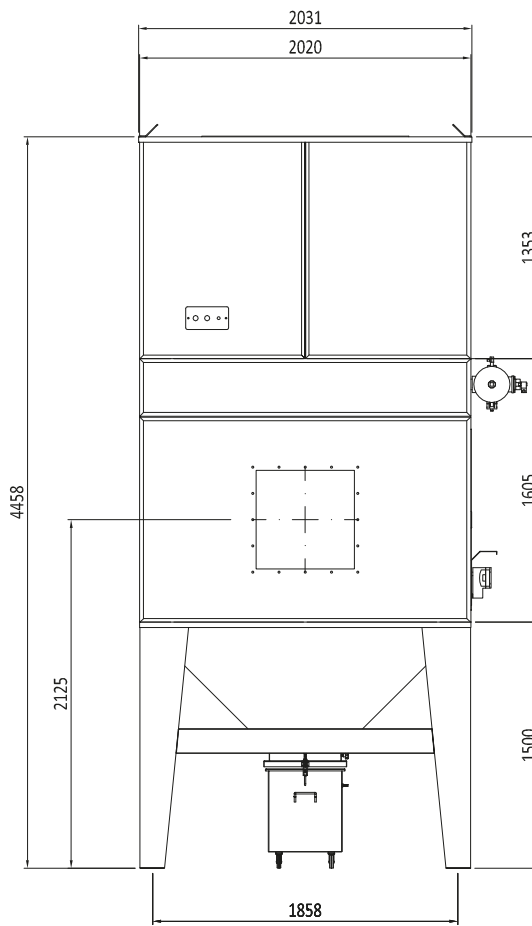
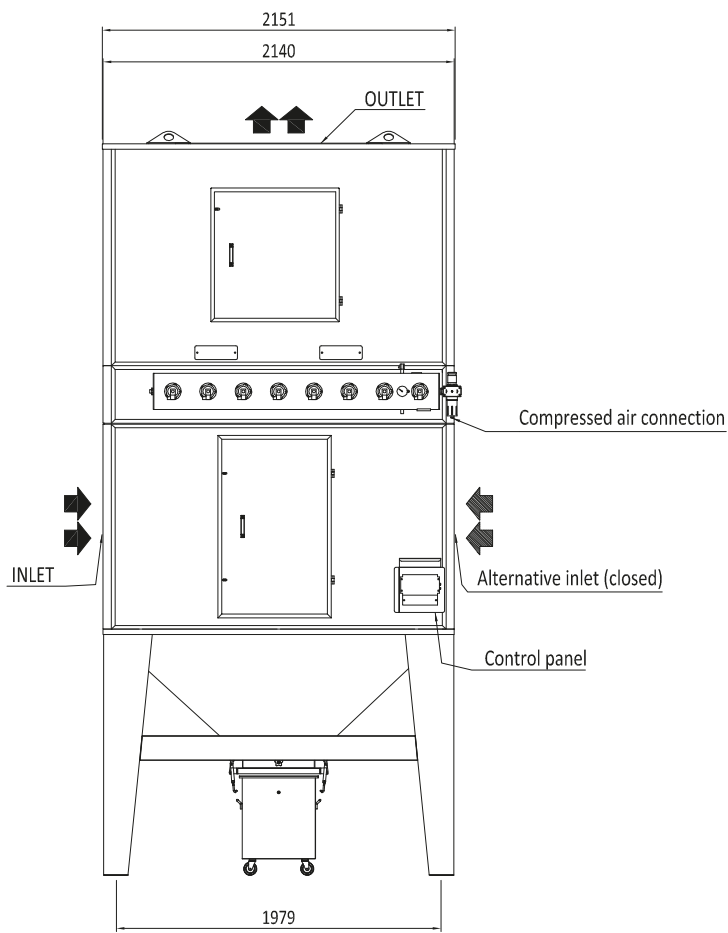

INLET FLANGE DETAIL

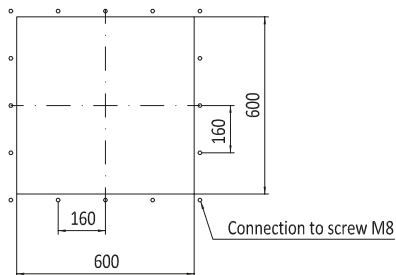

OUTLET FLANGE DETAIL

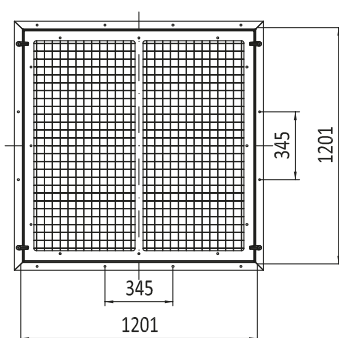

* The level of sound pressure is affected by the background noise, the reverberation of the environment, the presence of other sound sources and the positioning of the machine near reflecting surfaces. In the installations common conditions it is necessary to use corrective coefficients. This value depends also from the level of sound pressure of the fan.

| TECHNICAL SPECIFICATIONS | | |
|---|--|--------------|
| ITEM CODE | AC-DC 16000 | |
| Certification code | II 3 D Ex h III C T200°C Dc -10°C:T:40°C | |
| Weight | kg | 2300 |
| Number of filtering elements | nr | 16 |
| Filtering surface | m ² | 240 |
| Max working negative pressure | Pa | 5000 |
| Working Temperature | °C | -10:T:40 |
| Pneumatic feeding (ISO Class 2.4.1 according 8573-1:2010) | Ø | 1"1/2 GAS |
| Electric fan feeding | 400tr / 690st V AC 50 Hz | |
| Electric control panel feeding | 230 V AC 50Hz | |
| Cartridge cleaning system | pulse-jet | |
| Number of cleaning valves | nr | 8 |
| Type of cleaning valves | Ø 1" 1/2 - 24 V DC | |
| Compressed air tank working pressure | bar | 5 |
| PERFORMANCE CHARACTERISTICS | | |
| Nominal air flow | m ³ /h | 16000 |
| Nominal static pressure | Pa | 4730 |
| Nominal fan power | kW | 30 |
| Max compressed air consumption | NI/min | 651 |
| Average level of sound pressure LpA_1.5m (UNIS EN ISO 3746:1997) | dB(A) | <80 |

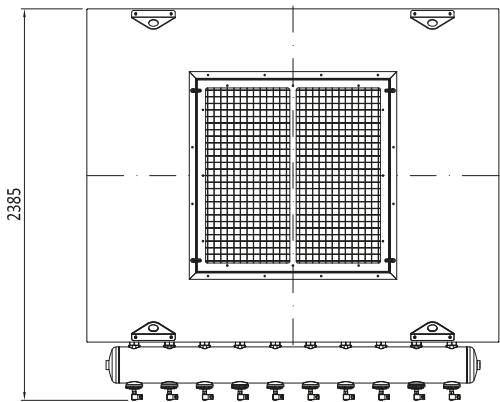
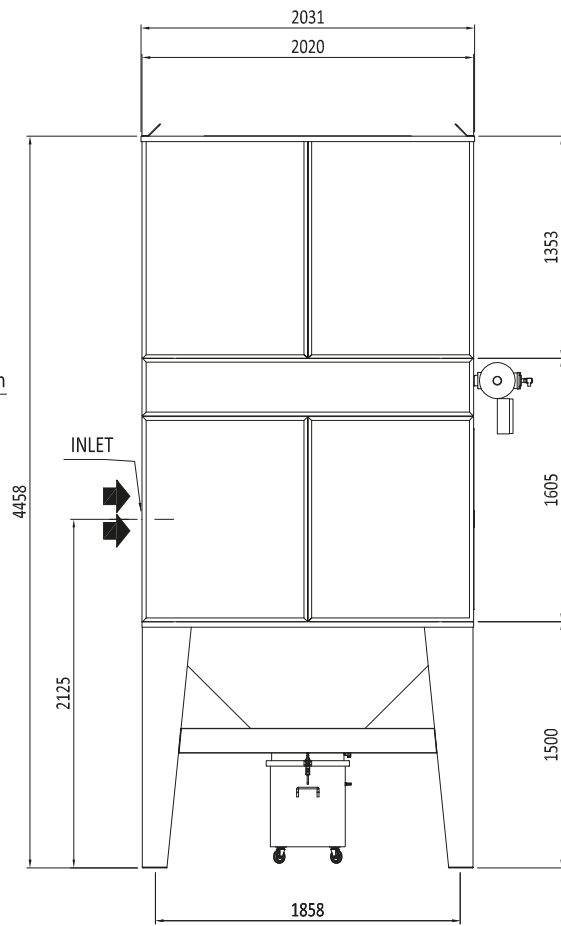
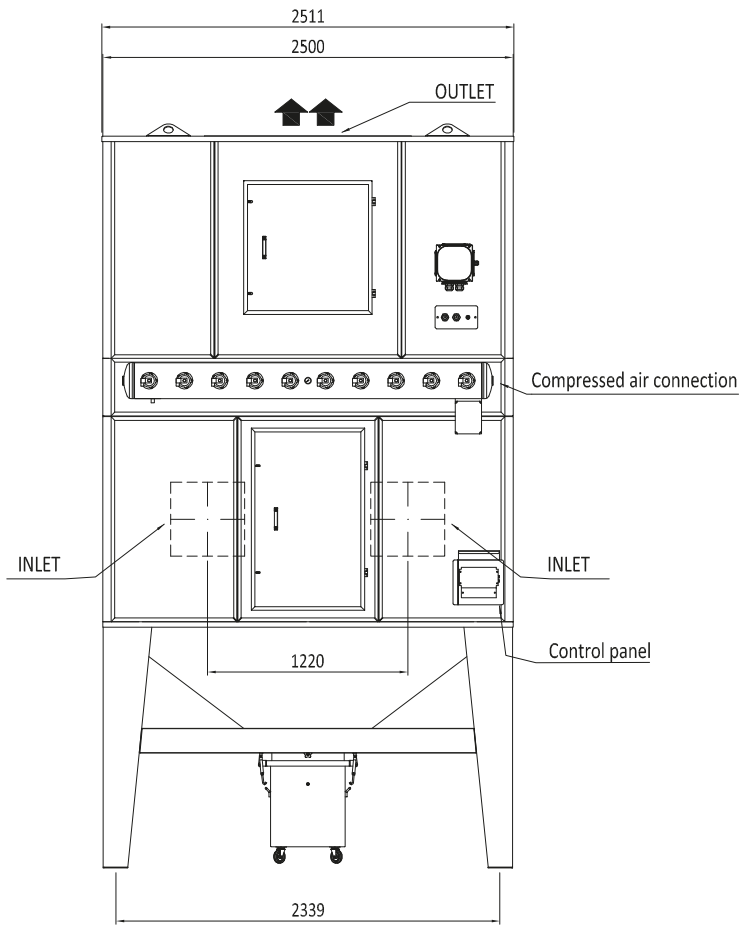

INLET FLANGE DETAIL

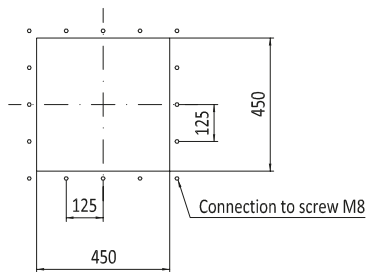

OUTLET FLANGE DETAIL

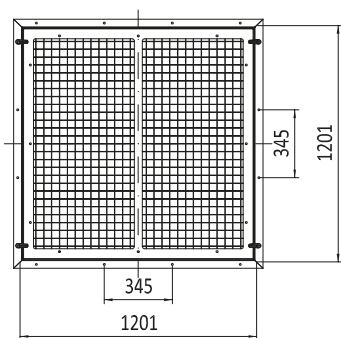

* The level of sound pressure is affected by the background noise, the reverberation of the environment, the presence of other sound sources and the positioning of the machine near reflecting surfaces. In the installations common conditions it is necessary to use corrective coefficients. This value depends also from the level of sound pressure of the fan.

| TECHNICAL SPECIFICATIONS | | |
|--|--|------------|
| ITEM CODE | AC-DC 20000 | |
| Certification code | II 3 D Ex h III C T200°C Dc -10°C:T:40°C | |
| Weight | kg | 2600 |
| Number of filtering elements | nr | 20 |
| Filtering surface | m ² | 300 |
| Max working negative pressure | Pa | 5000 |
| Working Temperature | °C | -10:T:40 |
| Pneumatic feeding (ISO Class 2.4.1 according 8573-1:2010) | Ø | 1" 1/2 GAS |
| Electric fan feeding | 400tr / 690st V AC 50 Hz | |
| Electric control panel feeding | 230 V AC 50Hz | |
| Cartridge cleaning system | pulse-jet | |
| Number of cleaning valves | nr | 10 |
| Type of cleaning valves | Ø 1" 1/2 - 24 V DC | |
| Compressed air tank working pressure | bar | 5 |
| PERFORMANCE CHARACTERISTICS | | |
| Nominal air flow | m ³ /h | 20000 |
| Nominal static pressure | Pa | 4100 |
| Nominal fan power | kW | 37 |
| Max compressed air consumption | NI/min | 651 |
| Average level of sound pressure LpA_1.5m (UNIS EN ISO 3746:1997) | dB(A) | <80 |

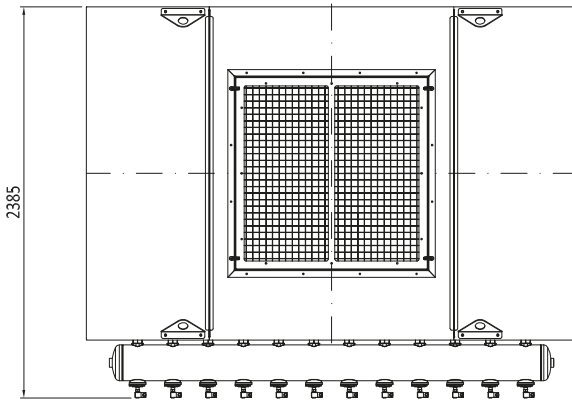
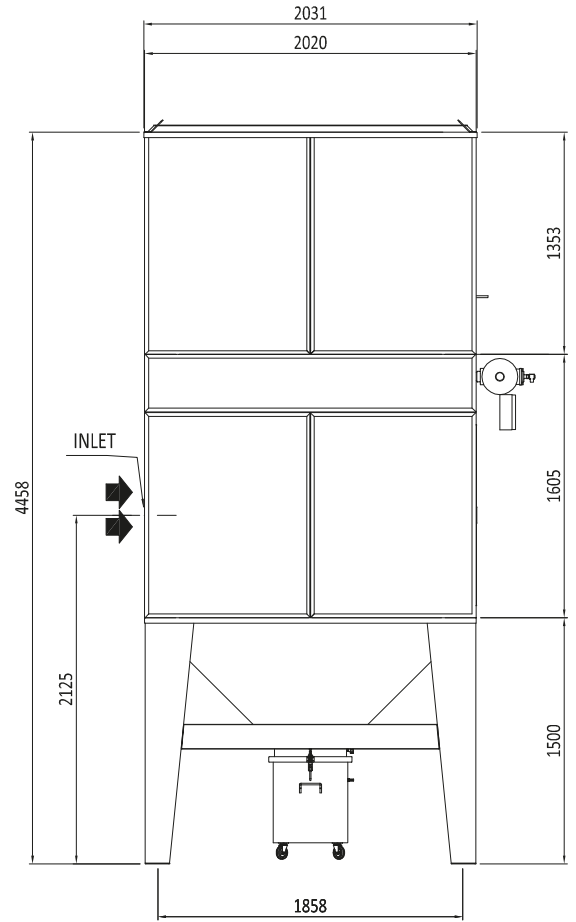
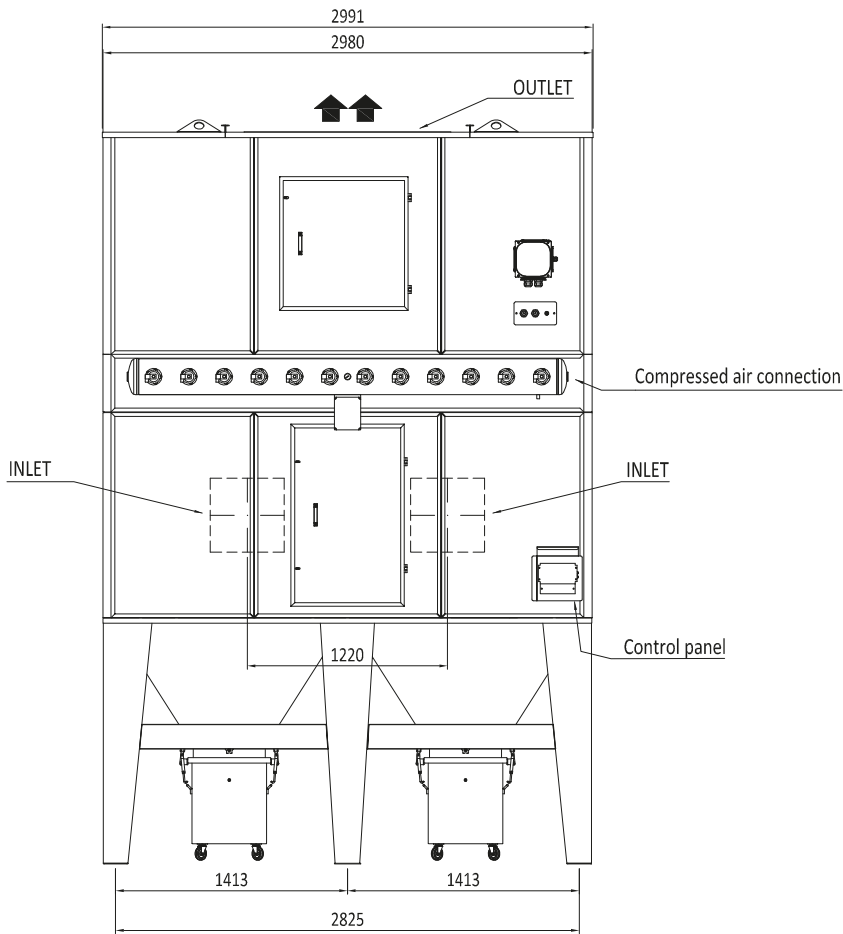

INLET FLANGE DETAIL

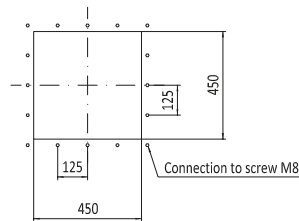

OUTLET FLANGE DETAIL

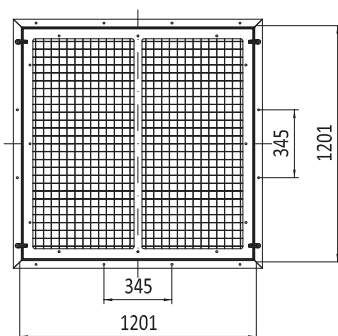

* The level of sound pressure is affected by the background noise, the reverberation of the environment, the presence of other sound sources and the positioning of the machine near reflecting surfaces. In the installations common conditions it is necessary to use corrective coefficients. This value depends also from the level of sound pressure of the fan.

TECHNICAL SPECIFICATIONS

| ITEM CODE | | AC-DC 24000 | |
|--|-------------------|--|--|
| Certification code | | II 3 D Ex h III C T200°C Dc -10°C:T<40°C | |
| Weight | kg | 2900 | |
| Number of filtering elements | nr | 24 | |
| Filtering surface | m ² | 360 | |
| Max working negative pressure | Pa | 5000 | |
| Working Temperature | °C | -10<T<40 | |
| Pneumatic feeding (ISO Class 2.4.1 according 8573-1:2010) | Ø | 1" 1/2 GAS | |
| Electric fan feeding | | 400tr / 690st V AC 50 Hz | |
| Electric control panel feeding | | 230 V AC 50Hz | |
| Cartridge cleaning system | | pulse-jet | |
| Number of cleaning valves | nr | 12 | |
| Type of cleaning valves | | Ø 1" 1/2 - 24 V DC | |
| Compressed air tank working pressure | bar | 5 | |
| PERFORMANCE CHARACTERISTICS | | | |
| Nominal air flow | m ³ /h | 24000 | |
| Nominal static pressure | Pa | 4800 | |
| Nominal fan power | kW | 45 | |
| Max compressed air consumption | NI/min | 651 | |
| Average level of sound pressure LpA_1.5m (UNIS EN ISO 3746:1997) | dB(A) | <80 | |

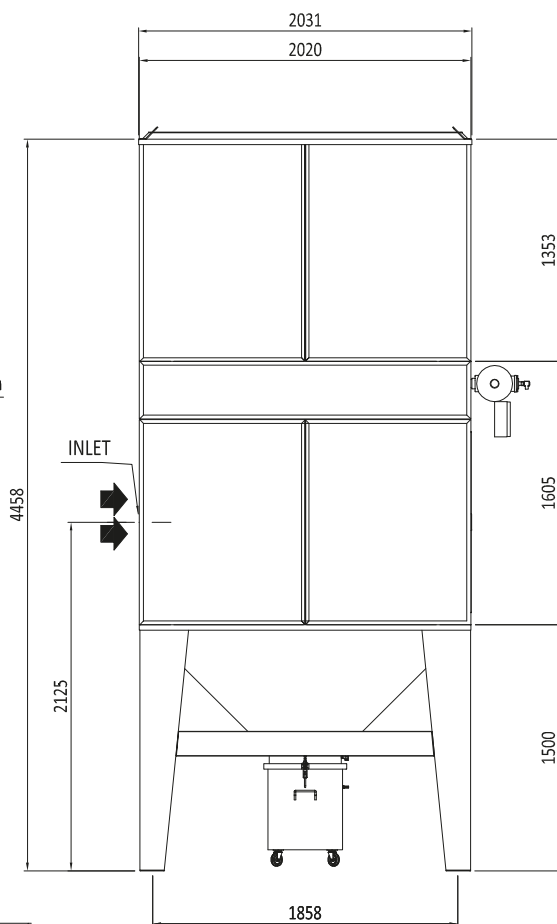
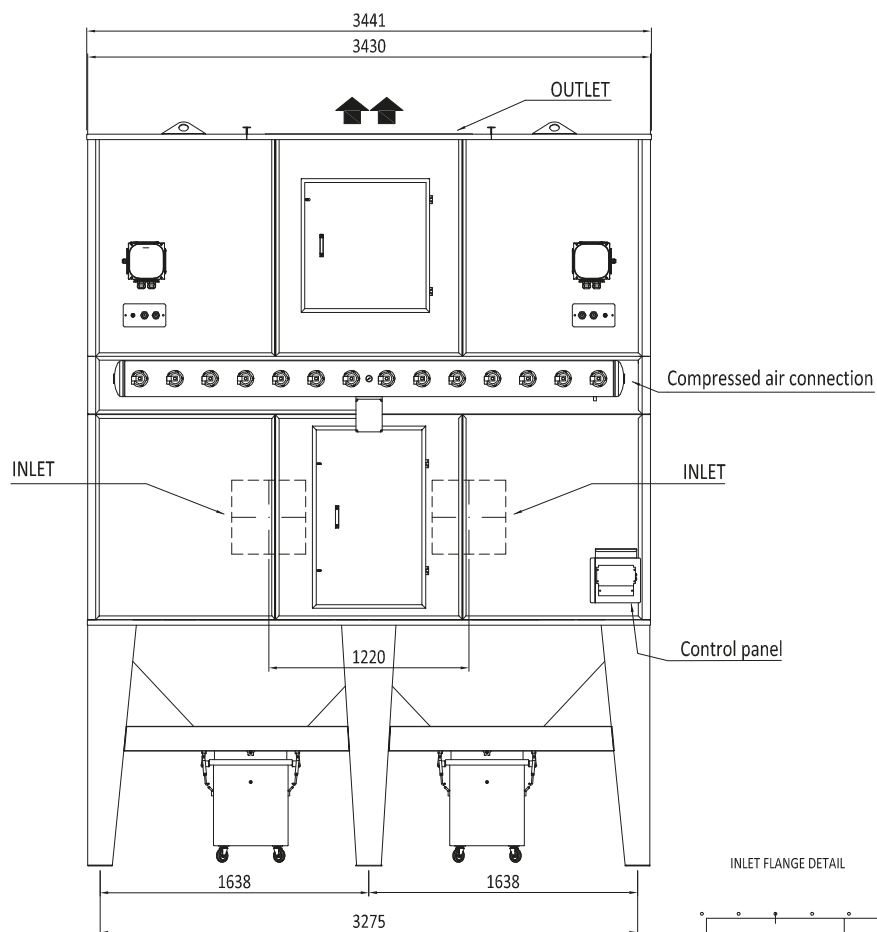

INLET FLANGE DETAIL

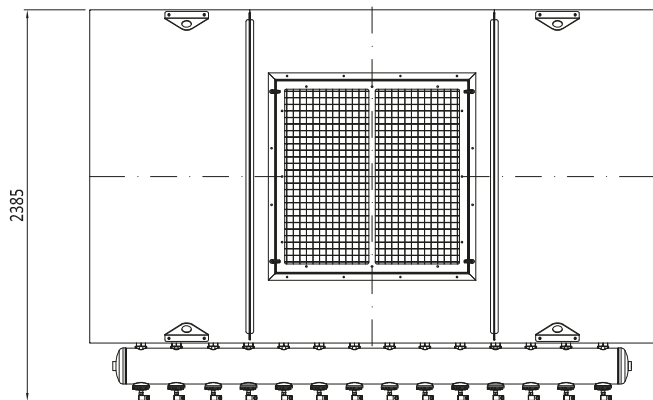
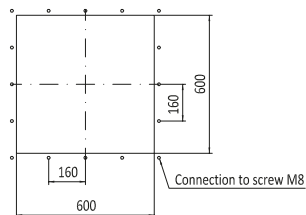

OUTLET FLANGE DETAIL

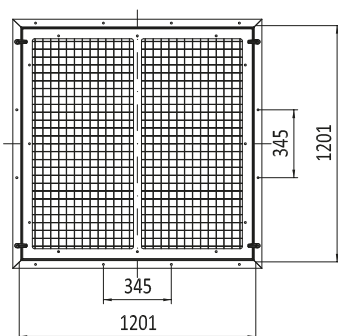

* The level of sound pressure is affected by the background noise, the reverberation of the environment, the presence of other sound sources and the positioning of the machine near reflecting surfaces. In the installations common conditions it is necessary to use corrective coefficients. This value depends also from the level of sound pressure of the fan.

| TECHNICAL SPECIFICATIONS | | |
|--|--|-----------|
| ITEM CODE | AC-DC 28000 | |
| Certification code | II 3 D Ex h III C T200°C Dc -10°C:T:40°C | |
| Weight | kg | 3200 |
| Number of filtering elements | nr | 28 |
| Filtering surface | m ² | 420 |
| Max working negative pressure | Pa | 5200 |
| Working Temperature | °C | -10<T:40 |
| Pneumatic feeding (ISO Class 2.4.1 according 8573-1:2010) | Ø | 1"1/2 GAS |
| Electric fan feeding | 400tr / 690st V AC 50 Hz | |
| Electric control panel feeding | 230 V AC 50Hz | |
| Cartridge cleaning system | pulse-jet | |
| Number of cleaning valves | nr | 14 |
| Type of cleaning valves | Ø 1" 1/2 - 24 V DC | |
| Compressed air tank working pressure | bar | 5 |
| PERFORMANCE CHARACTERISTICS | | |
| Nominal air flow | m ³ /h | 28000 |
| Nominal static pressure | Pa | 5100 |
| Nominal fan power | kW | 60 (2x30) |
| Max compressed air consumption | NI/min | 651 |
| Average level of sound pressure LpA_1.5m (UNIS EN ISO 3746:1997) | dB(A) | <80 |

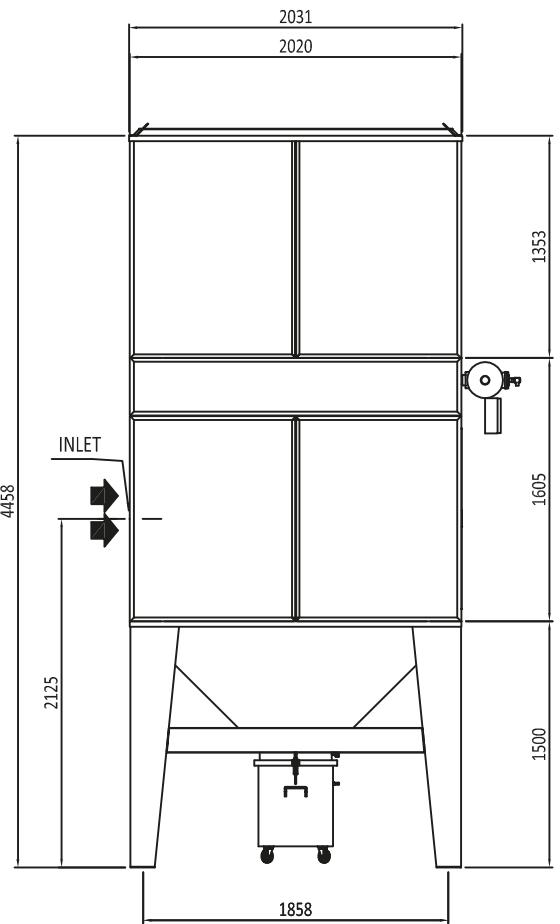
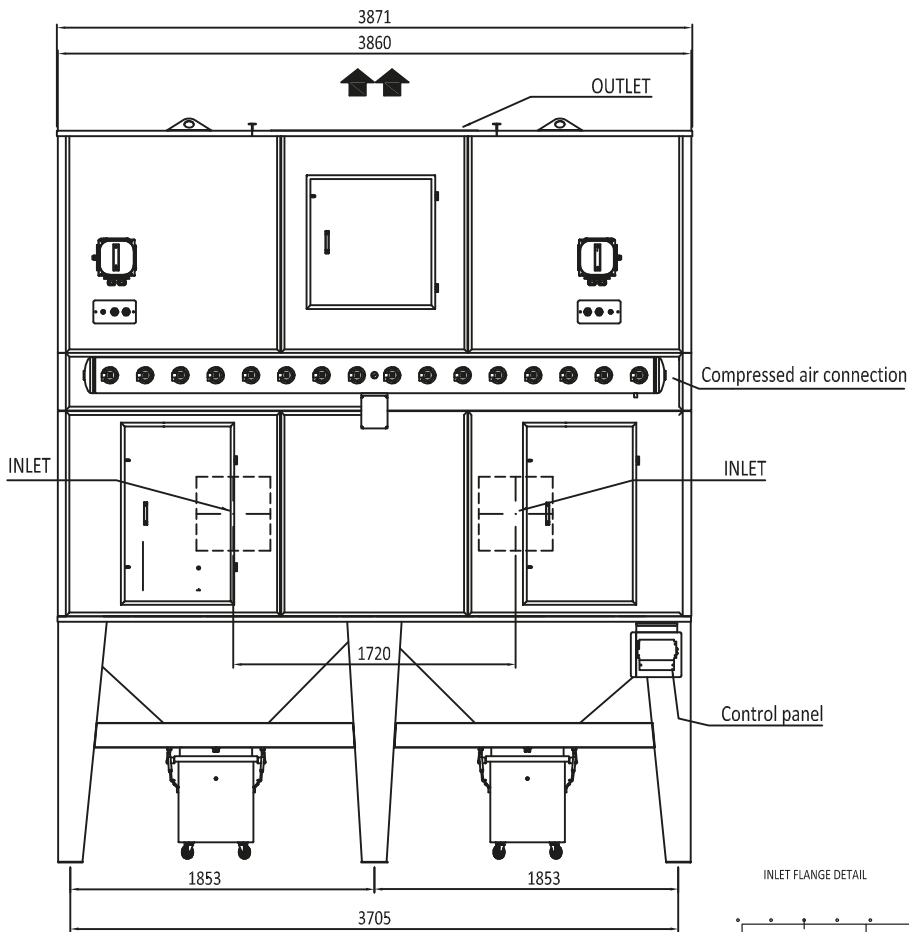

INLET FLANGE DETAIL

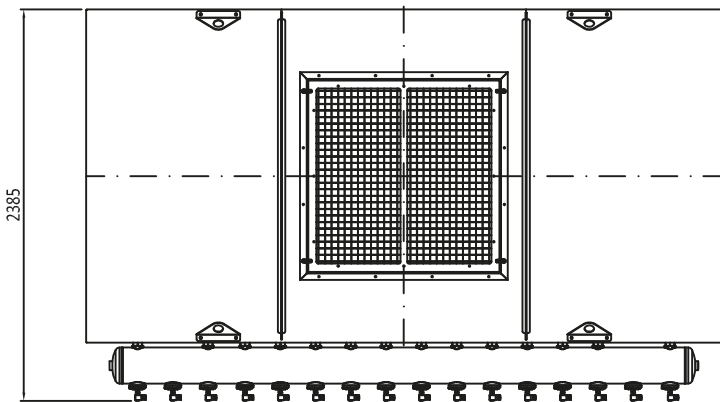
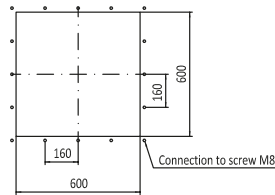

OUTLET FLANGE DETAIL

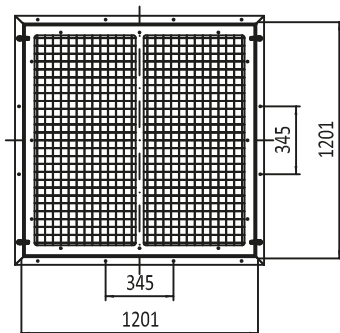

* The level of sound pressure is affected by the background noise, the reverberation of the environment, the presence of other sound sources and the positioning of the machine near reflecting surfaces. In the installations common conditions it is necessary to use corrective coefficients. This value depends also from the level of sound pressure of the fan.

TECHNICAL SPECIFICATIONS

| ITEM CODE | | AC-DC 32000 | |
|---|-----------------------------|--|--|
| Certification code | | II 3 D Ex h III C T200°C Dc -10°C:T:40°C | |
| Weight | kg | 3600 | |
| Number of filtering elements | nr | 32 | |
| Filtering surface | m ² | 480 | |
| Max working negative pressure | Pa | 5000 | |
| Working Temperature | °C | -10:T:40 | |
| Pneumatic feeding (ISO Class 2.4.1 according 8573-1:2010) | Ø | 1"1/2 GAS | |
| Electric fan feeding | 400tr / 690st V AC 50 Hz | | |
| Electric control panel feeding | 230 V AC 50Hz | | |
| Cartridge cleaning system | pulse-jet | | |
| Number of cleaning valves | nr | 16 | |
| Type of cleaning valves | Ø 1" 1/2 - 24 V DC | | |
| Compressed air tank working pressure | bar | 5 | |
| PERFORMANCE CHARACTERISTICS | | | |
| Nominal air flow | m ³ /h | 32000 | |
| Nominal static pressure | Pa | 4730 | |
| Nominal fan power | kW | 60 (2x30) | |
| Max compressed air consumption | NI/min | 651 | |
| Average level of sound pressure LpA_1.5m (UNIS EN ISO 3746:1997) | dB(A) | <80 | |